

PRODUCT SPECIFICATION

4.6" TN TFT LCD MODULE

MODEL: T046800480-A10TMN-001 Ver:1.0



< ◇ > Preliminary Specification

< ◆ > Finally Specification

CUSTOMER'S APPROVAL	
CUSTOMER :	
SIGNATURE:	DATE:

APPROVED BY	PM REVIEWED	PD REVIEWED	PREPARED BY

Revision History

Revision	Date	Originator	Detail	Remarks
1.0	2013.05.11		Initial Release	

Table of Contents

No.	Item	Page
1.	General Description.....	5
2.	Module Parameter.....	5
3.	Absolute Maximum Ratings.....	5
4.	DC Characteristics	6
5.	Backlight Characteristic.....	6
5.1.	Backlight Characteristics	6
5.2.	Backlighting circuit.....	6
6.	Optical Characteristics	7
6.1.	Optical Characteristics.....	7
6.2.	Definition of Response Time	7
6.3.	Definition of Contrast Ratio	8
6.4.	Definition of Viewing Angles	8
6.5.	Definition of Color Appearance.....	9
6.6.	Definition of Surface Luminance, Uniformity and Transmittance	9
7.	Block Diagram and Power Supply.....	10
8.	Interface Pins Definition	11
9.	Timing Chart.....	12
9.1.	Input Clock and Data Timing Diagram.....	12
9.2.	Timing Parameters	12
9.3.	Data Input format.....	13
9.3.1	Horizontal Input Timing Diagram	13
9.3.2	Vertical Input Timing Diagram	13
9.3.3	Parameter Setting Of Timing	14
9.4.	Power ON Sequence.....	14
9.5.	Power Off Sequence	15
9.6.	Power ON/Off Sequence	15
10.	Quality Assurance	16
10.1	Purpose	16
10.2	Standard for Quality Test	16
10.3	Nonconforming Analysis & Disposition.....	16
10.4	Agreement Items	16
10.5	Standard of the Product Visual Inspection	16
10.6	Inspection Specification.....	17
10.7	Classification of Defects	21
10.8	Identification/marketing criteria.....	21
10.9	Packing.....	21
11.	Reliability Specification.....	22
12.	Precautions and Warranty	23
12.1	Safety.....	23
12.2	Handling.....	23
12.3	Storage	23
12.4	Metal Pin (Apply to Products with Metal Pins).....	23
12.5	Operation.....	24

12.6	Static Electricity	24
12.7	Limited Warranty.....	24
13.	Packaging.....	25
14.	Outline Drawing.....	26

1. General Description

The specification is a transmissive type color active matrix liquid crystal display (LCD) which uses amorphous thin film transistor (TFT) as switching devices. This product is composed of a TFT-LCD panel, driver Ics and a backlight unit.

2. Module Parameter

Features	Details	Unit
Display Size(Diagonal)	4.6"	
LCD type	TN TFT	
Display Mode	Normally White/Transmissive	
Resolution	800 RGB x 320	Pixels
View Direction	12 O'clock	Best Image
Gray Scale Inversion Direction	6 O'clock	
Module Outline	120.7 (H) x 57.08(V) x 3.10(MAX)(T) (Note1)	mm
Active Area	108 (H) x 43.2(V)	mm
Pixel Size	135 (H) x 135(V)	um
Pixel Arrangement	R.G.B Vertical Stripe	
Polarizer Surface Treatment	Anti-Glare	
Display Colors	16.7M	
Interface	24-bit RGB interface	
Driver IC	HX8664&HX8264	
With or Without Touch Panel	Without	
Operating Temperature	-20~70	°C
Storage Temperature	-30~80	°C
Weight	TBD	g

Note 1: Exclusive hooks, posts , FFC/FPC tail etc.

3. Absolute Maximum Ratings

$V_{SS}=0V, T_a=25^{\circ}C$

Item	Symbol	Min.	Max.	Unit
Supply Voltage	VDD	-0.5	5.0	V
Back Light Forward Current	I_{LED}	-	25	mA /One LED
Storage temperature	T_{STG}	-30	+80	°C
Operating temperature	T_{OP}	-20	+70	°C

Note 1: If T_a below $50^{\circ}C$, the maximal humidity is 90%RH, if T_a over $50^{\circ}C$, absolute humidity should be less than 60%RH.

Note 2: The response time will be extremely slow when the operating temperature is around $-10^{\circ}C$, and the back ground will become darker at high temperature operating.

4. DC Characteristics

Item	Symbol	Min.	Typ.	Max.	Unit
Supply Voltage	VDD	3.0	3.3	3.6	V
Logic Low input voltage	V _{IL}	0	-	0.3*VDD	V
Logic High input voltage	V _{IH}	0.7*VDD	-	VDD	V
Logic Low output voltage	V _{OL}	-	-	VSS+0.4	V
Logic High output voltage	V _{OH}	VDD-0.4	-	-	V
(Panel+LSI) Power Consumption	Black Mode (60Hz)		TBD		mW
	Standby Mode		TBD		mW

5. Backlight Characteristic

5.1. Backlight Characteristics

Item	Symbol	Condition	Min	Typ	Max	Unit
Forward Voltage	V _F	Ta=25 °C, I _F =20mA/LED	-	19.6	-	V
Forward Current	I _F	Ta=25 °C, V _F =19.6V	-	20*3	25*3	mA
Power dissipation	P _D		-	1176	-	mW
Uniformity	Avg		75	80	-	%
Drive method	Constant current					
LED Configuration	18 White LEDs (6 LEDs in string and 3groups in parallel)					

5.2. Backlighting circuit

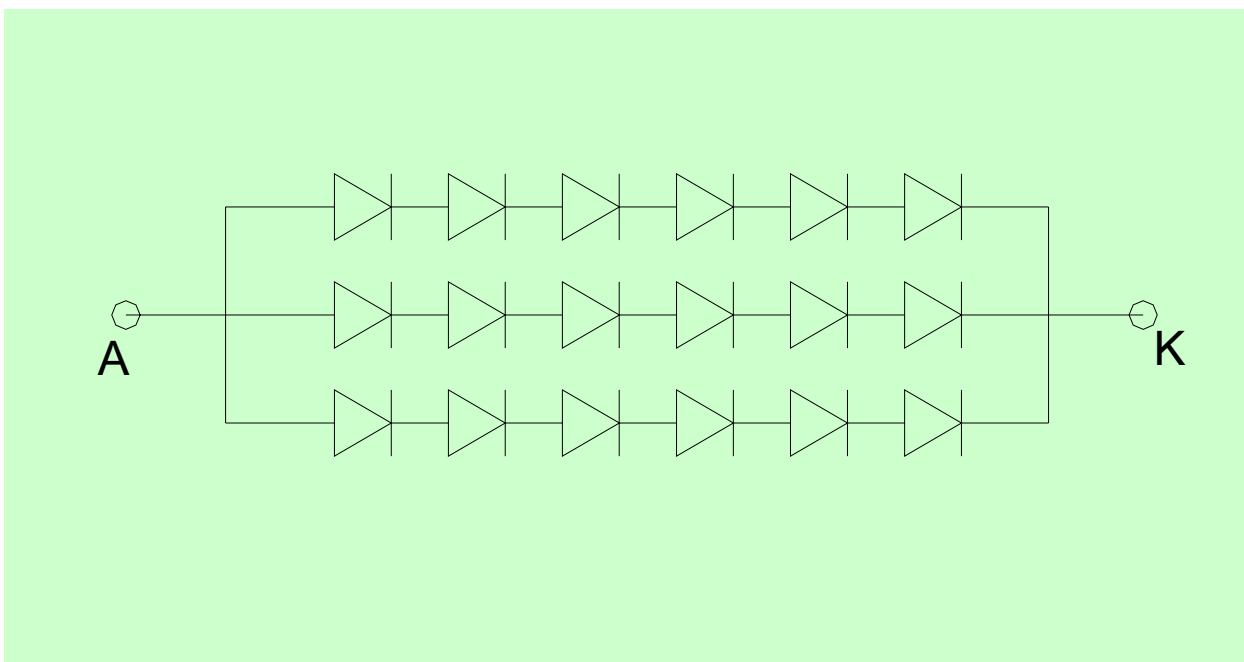

6. Optical Characteristics

6.1. Optical Characteristics

Ta=25°C, V_{DD}=3.3V, TN LC+ Polarizer

	Item	Symbol	Condition	Specification			Unit
				Min.	Typ.	Max.	
Backlight On (Transmissive Mode)	Luminance on TFT(I _f =20mA/LED)	Lv	Normally viewing angle θ _x = φ _y = 0°	320	400	-	cd/m ²
	Contrast ratio(See 6.3)	CR		400	500	-	
	Response time (See 6.2)	T _R		-	25	30	ms
		T _F					
	Chromaticity Transmissive (See 6.5)	Red	X _R	0.540	0.590	0.640	
			Y _R	0.300	0.350	0.400	
		Green	X _G	0.298	0.348	0.398	
			Y _G	0.520	0.570	0.620	
		Blue	X _B	0.100	0.150	0.200	
			Y _B	0.050	0.100	0.150	
	White	X _W	0.260	0.310	0.360		
		Y _W	0.280	0.330	0.380		
	Viewing Angle (See 6.4)	Horizontal	θ _{x+}	60	70	-	Deg.
θ _{x-}			60	70	-		
Vertical		φ _{y+}	40	50	-		
		φ _{y-}	60	70	-		
NTSC Ratio(Gamut)			40	50	-	%	

6.2. Definition of Response Time

6.2.1. Normally Black Type (Negative)

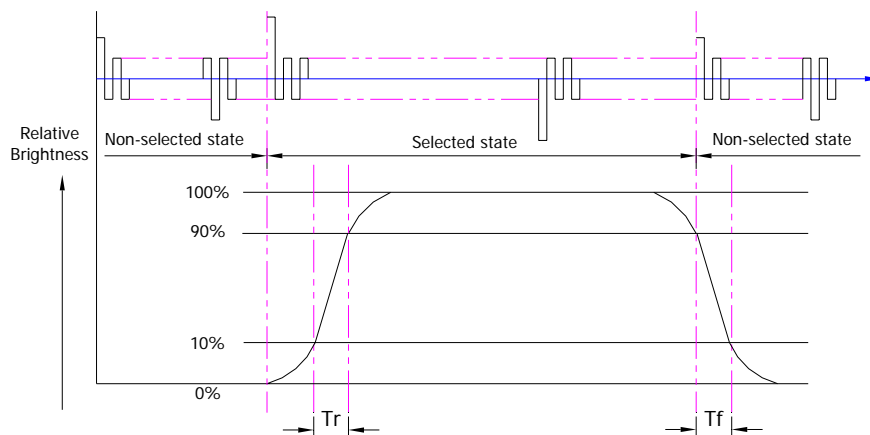

Tr is the time it takes to change from non-selected stage with relative luminance 10% to selected state with relative luminance 90%;

Tf is the time it takes to change from selected state with relative luminance 90% to

non-selected state with relative luminance 10%

Note : Measuring machine: LCD-5100

6.2.2. Normally White Type (Positive)

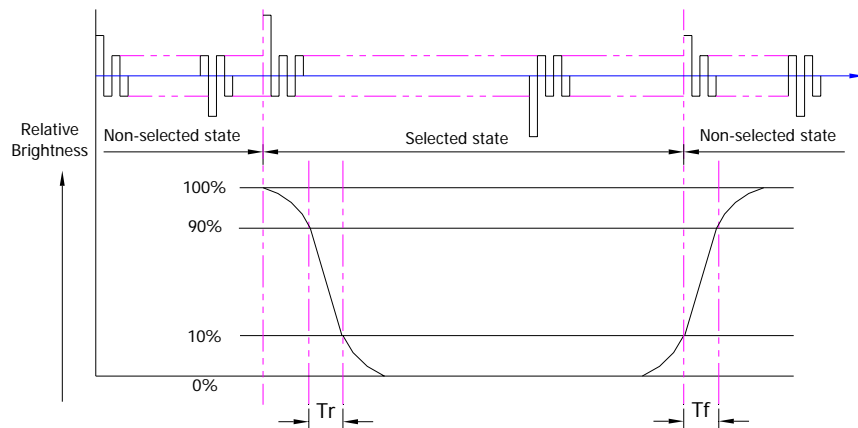

Tr is the time it takes to change from non-selected state with relative luminance 90% to selected state with relative luminance 10%;

Tf is the time it takes to change from selected state with relative luminance 10% to non-selected state with relative luminance 90%;

Note : Measuring machine: LCD-5100 or EQUI

6.3. Definition of Contrast Ratio

Contrast is measured perpendicular to display surface in reflective and transmissive mode.

The measurement condition is:

Measuring Equipment	Eldim or Equivalent
Measuring Point Diameter	3mm//1mm
Measuring Point Location	Active Area centre point
Test pattern	A: All Pixels white
	B: All Pixel black
Contrast setting	Maximum

Definitions: CR (Contrast) = Luminance of White Pixel / Luminance of Black Pixel

6.4. Definition of Viewing Angles

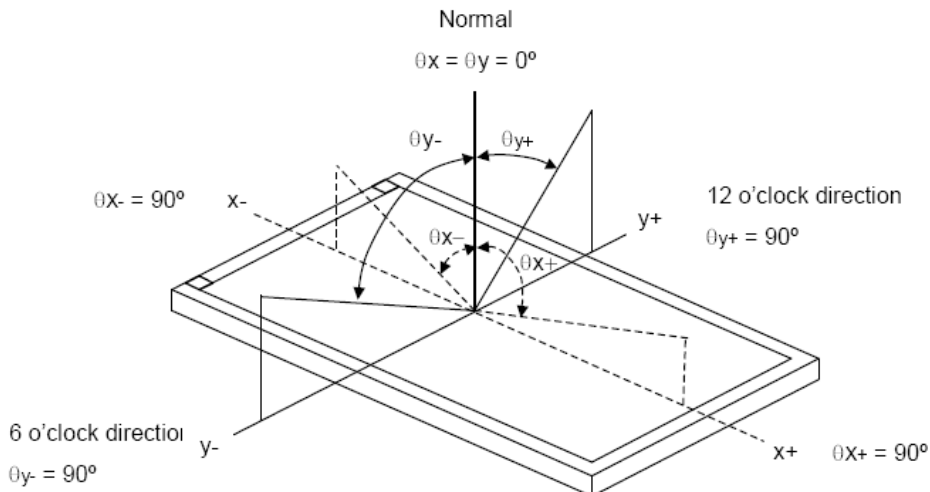

Measuring machine: LCD-5100 or EQUI

6.5. Definition of Color Appearance

R,G,B and W are defined by (x, y) on the IE chromaticity diagram

NTSC=area of RGB triangle/area of NTSC triangleX100%

Measuring picture: Red, Green, Blue and White (Measuring machine: BM-7)

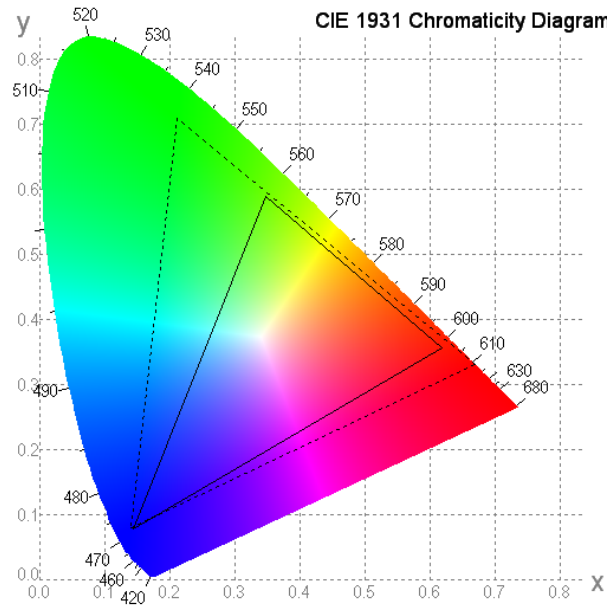

6.6. Definition of Surface Luminance, Uniformity and Transmittance

Using the transmissive mode measurement approach, measure the white screen luminance of the display panel and backlight.

6.6.1. Surface Luminance: $L_V = \text{average } (L_{P1}:L_{P9})$

6.6.2. Uniformity = Minimal ($L_{P1}:L_{P9}$) / Maximal ($L_{P1}:L_{P9}$) * 100%

6.6.3. Transmittance = L_V on LCD / L_V on Backlight * 100%

Note : Measuring machine: BM-7

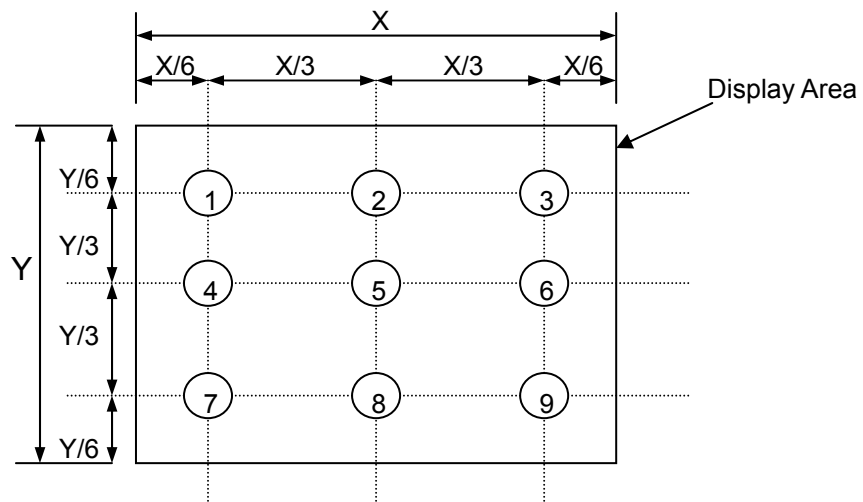

7. Block Diagram and Power Supply

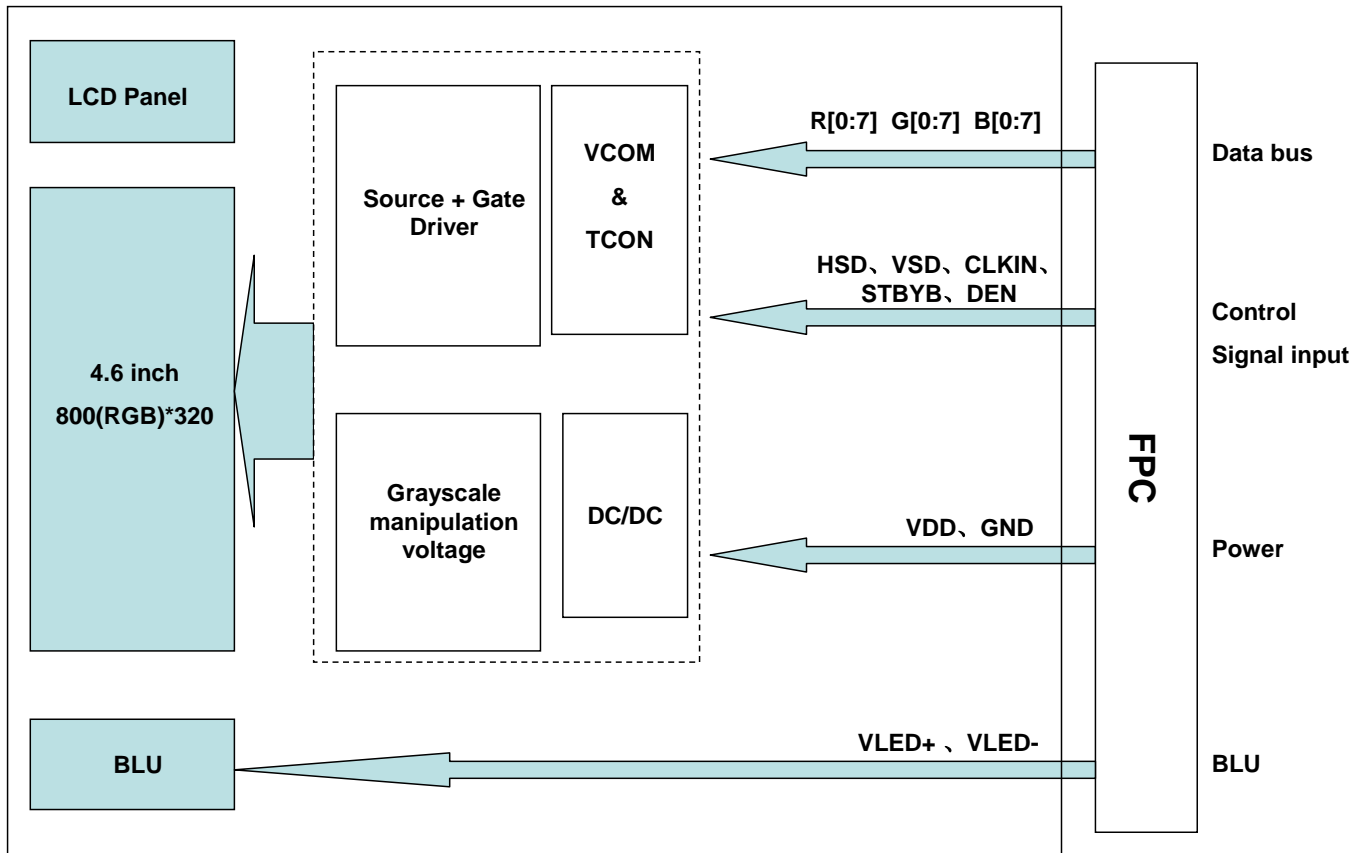

8. Interface Pins Definition

No.	Symbol	Function	Remark
1	VLED-	Ground(Cathode)	
2	VLED+	LED Input Terminal(Anode)	
3	GND	Ground	
4	VDD	Power voltage	
5	R0	Red data(LSB)	
6	R1	Red data	
7	R2	Red data	
8	R3	Red data	
9	R4	Red data	
10	R5	Red data	
11	R6	Red data	
12	R7	Red data(MSB)	
13	G0	Green data(LSB)	
14	G1	Green data	
15	G2	Green data	
16	G3	Green data	
17	G4	Green data	
18	G5	Green data	
19	G6	Green data	
20	G7	Green data(MSB)	
21	B0	Blue data(LSB)	
22	B1	Blue data	
23	B2	Blue data	
24	B3	Blue data	
25	B4	Blue data	
26	B5	Blue data	
27	B6	Blue data	
28	B7	Blue data(MSB)	
29	GND	Ground	
30	CLKIN	Clock for input data.Data latched at rising edge of this signal	
31	STBYB	Display on/off	
32	HSD	Horizontal sync signal	
33	VSD	Vertical sync signal	
34	DEN	Data enable	
35	NC	No connection	
36	GND	Ground	
37	NC(XR)	No connection	
38	NC(YD)	No connection	
39	NC(XL)	No connection	
40	NC(YU)	No connection	

9. Timing Chart

9.1. Input Clock and Data Timing Diagram

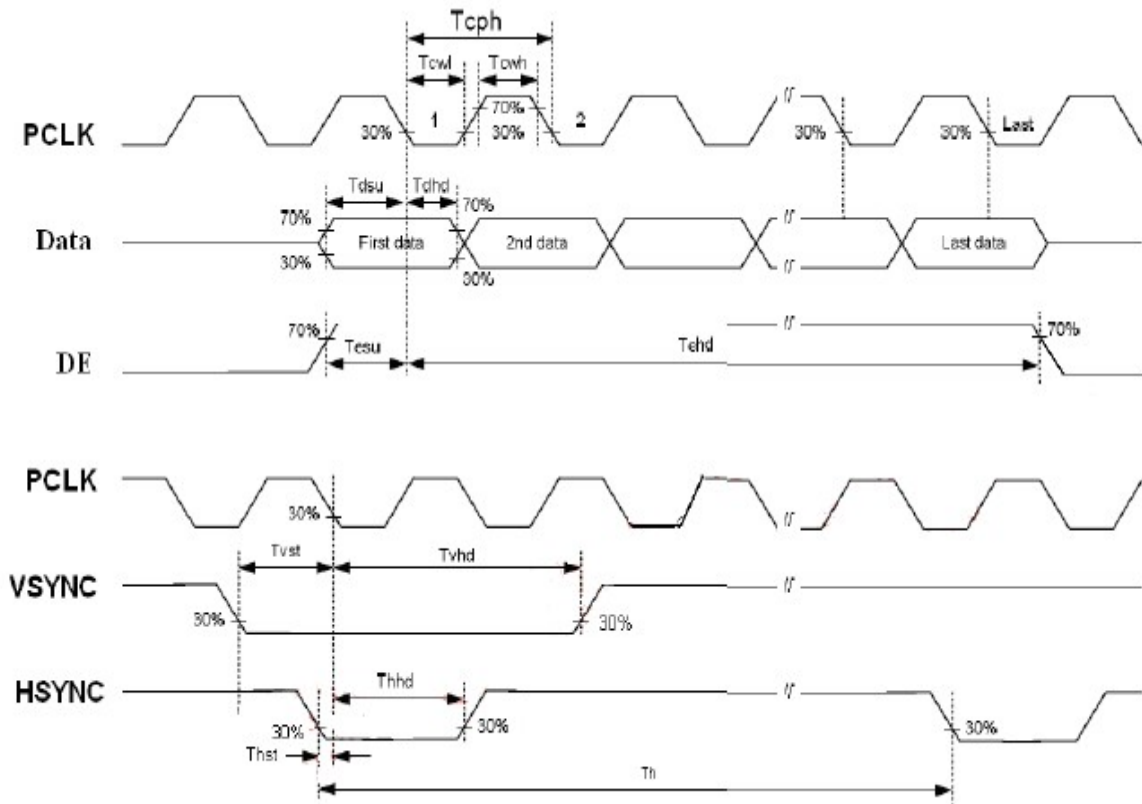

9.2. Timing Parameters

Normal Write Mode

VDD=3.3V Ta=25°C

Parameter	Symbol	Min	Typ	Max	Unit	Remark
HSYNC Setup Time	T_{hst}	8	--	--	ns	
HSYNC Hold Time	T_{hhd}	8	--	--	ns	
VSYNC Setup Time	T_{vst}	8	--	--	ns	
VSYNC Hold Time	T_{vhhd}	8	--	--	ns	
Data Setup Time	T_{dsu}	8	--	--	ns	
Data Hold Time	T_{dhd}	8	--	--	ns	
DE Setup Time	T_{esu}	8	--	--	ns	
DE Hold Time	T_{ehd}	8	--	--	ns	
PCLK Cycle Time	T_{cph}	20	--	--	ns	
PCLK Pulse Width	T_{cwh}	40	50	60	%	
Output stable time	T_{sst}	--	-	6	us	
VDD Power ON Slew rate	T_{por}		--	20	ms	
RSTB pulse width	T_{rst}	10	--	--	us	

9.3. Data Input format

9.3.1 Horizontal Input Timing Diagram

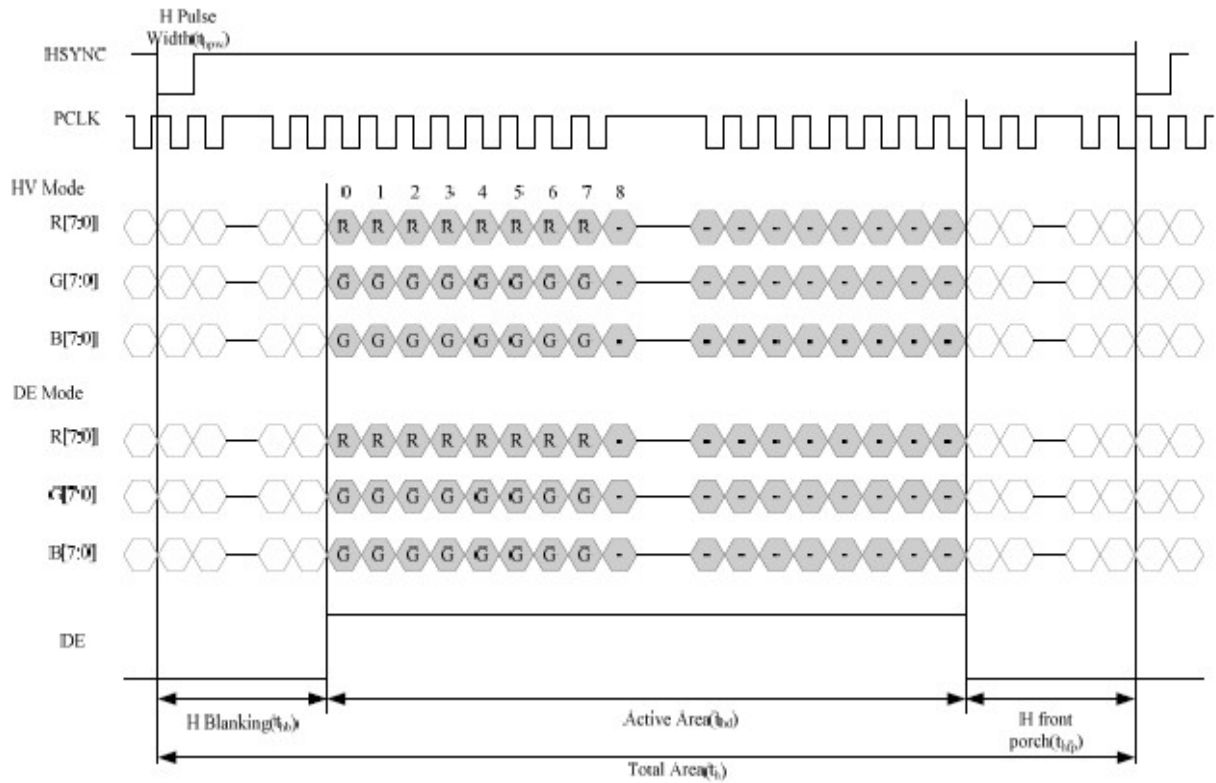

9.3.2 Vertical Input Timing Diagram

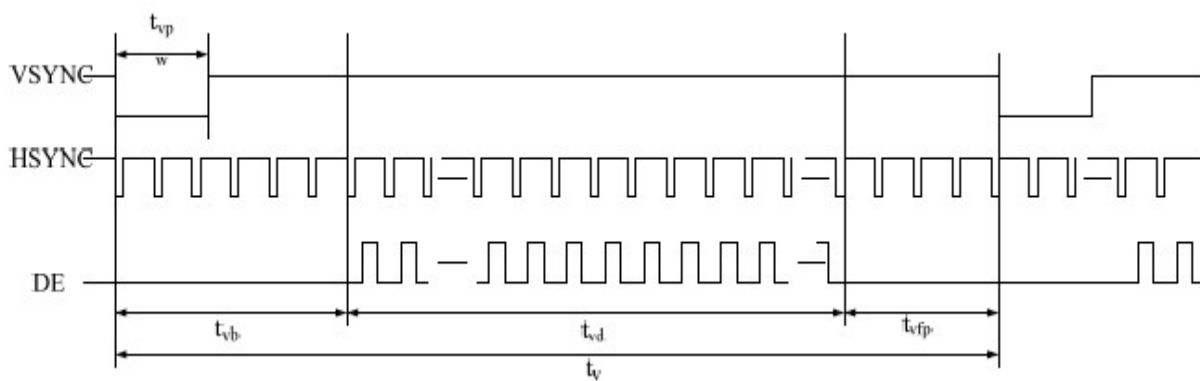

9.3.3 Parameter Setting Of Timing

Parameter	Symbol	Spec			Unit
		Min.	Typ.	Max.	
Horizontal display area	t_{hd}	800			PCLK
PCLK frequency(60Hz)	t_{clk}	-	21	42	MHZ
One Horizontal Line	t_h	889	928	1143	PCLK
HSYNC pulse width	t_{hpw}	1	48	255	PCLK
HSYNC blanking	t_{hb}	88			PCLK
HSYNC front porch	t_{hfp}	1	40	255	PCLK
Vertical display area	t_{vd}	332			T_H
VSYNC period time	t_v	365	377	619	T_H
VSYNC pulse width	t_{hd}	3	3	255	T_H
VSYNC blanking(tv _b)	t_{vpw}	32			T_H
VSYNC front porch(tv _{fp})	t_{yfp}	1	13	255	T_H

9.4. Power ON Sequence

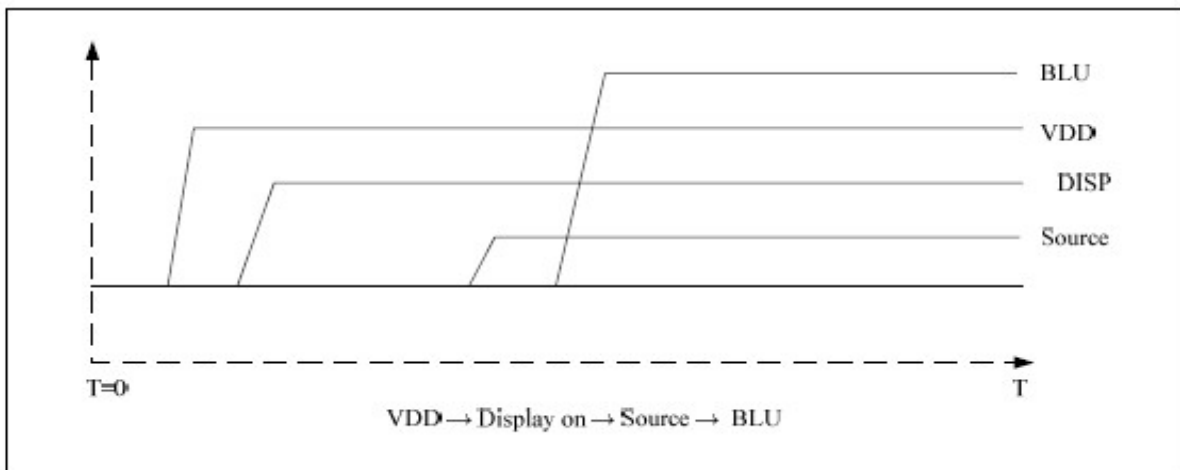

9.5. Power Off Sequence

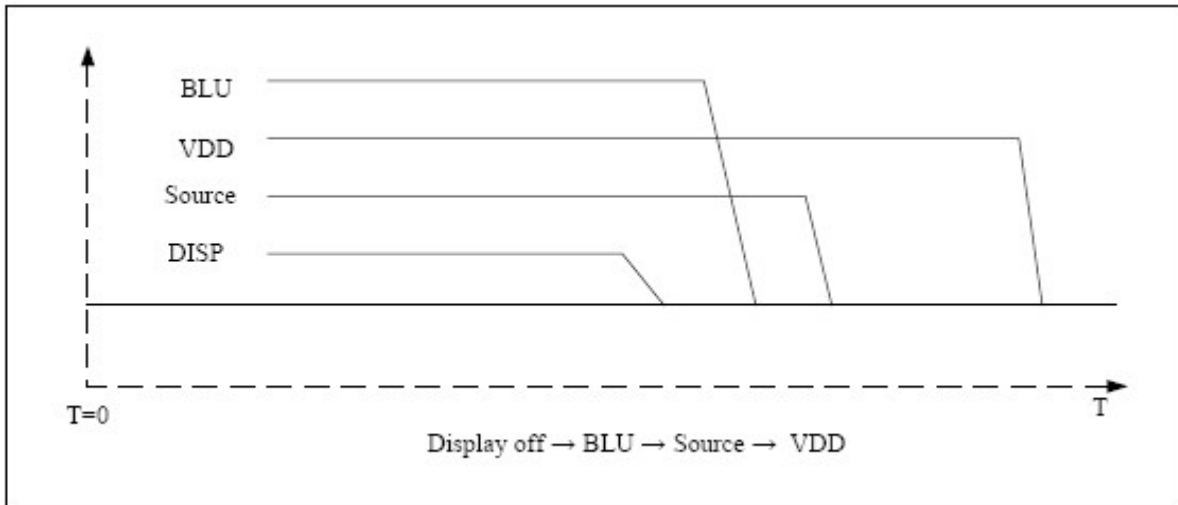

9.6. Power ON/Off Sequence

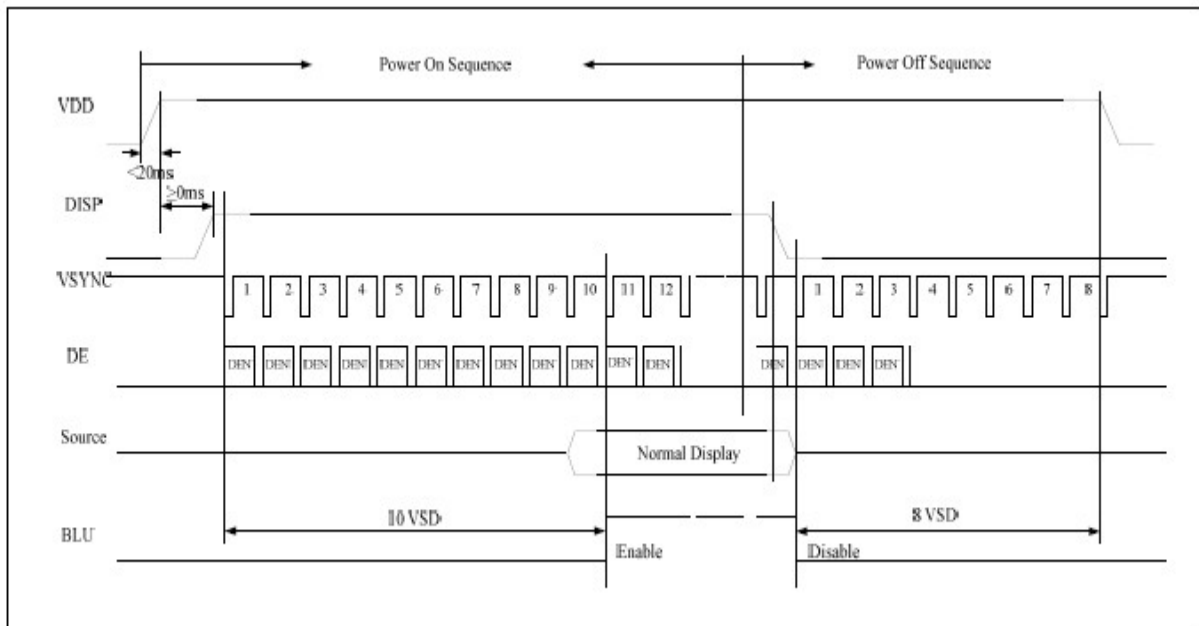

10. Quality Assurance

10.1 Purpose

This standard for Quality Assurance assures the quality of LCD module products supplied to customer.

10.2 Standard for Quality Test

10.2.1 Sampling Plan:

ANSI / ASQC Z1.4-1993.

Single sampling, normal inspection.

10.2.2 Sampling Criteria:

Visual inspection: AQL 1.5%

Electrical functional: AQL 0.65%.

10.2.3 Reliability Test:

Detailed requirement refer to Reliability Test Specification.

10.3 Nonconforming Analysis & Disposition

10.3.1 Nonconforming analysis:

10.3.1.1 Customer should provide overall information of non-conforming sample for their complaints.

10.3.1.2 After receipt of detailed information from customer, the analysis of nonconforming parts usually should be finished in one week.

10.3.1.3 If can not finish the analysis on time, customer will be notified with the progress status.

10.3.2 Disposition of nonconforming:

10.3.2.1 Non-conforming product over PPM level will be replaced.

10.3.2.2 The cause of non-conformance will be analyzed. Corrective action will be discussed and implemented.

10.4 Agreement Items

Shall negotiate with customer if the following situation occurs:

10.4.1 There is any discrepancy in standard of quality assurance.

10.4.2 Additional requirement to be added in product specification.

10.4.3 Any other special problem.

10.5 Standard of the Product Visual Inspection

10.5.1 Appearance inspection:

10.5.1.1 The inspection must be under illumination about 1000 – 1500 lx, and the distance of view must be at 30cm ± 2cm.

10.5.1.2 The viewing angle should be 45° from the vertical line without reflection light or follows customer's viewing angle specifications.

10.5.1.3 Definition of area: A Zone: Active Area, B Zone: Viewing Area,

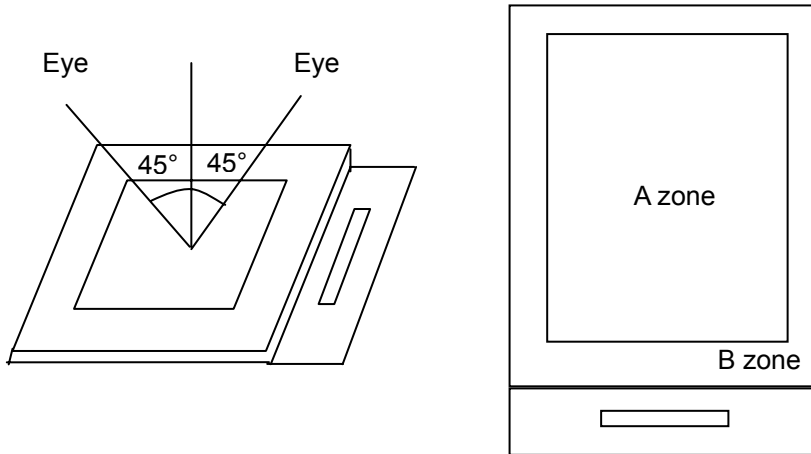

10.5.2 Basic principle:

10.5.2.1 A set of sample to indicate the limit of acceptable quality level must be discussed by both us and customer when there is any dispute happened.

10.5.2.2 New item must be added on time when it is necessary.

10.6 Inspection Specification

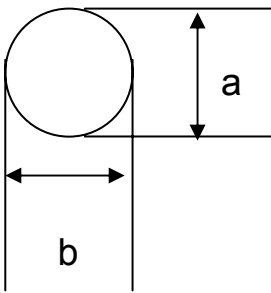
No.	Item	Criteria (Unit: mm)																	
01	Black / White spot Foreign material (Round type) Pinholes Stain Particles inside cell. (Minor defect)	 $\phi = (a + b) / 2$		<table border="1" data-bbox="900 1075 1402 1294"> <thead> <tr> <th>Size</th> <th>Area</th> <th>Acc. Qty</th> </tr> </thead> <tbody> <tr> <td>$\phi \leq 0.20$</td> <td></td> <td>Ignore</td> </tr> <tr> <td>$0.20 < \phi \leq 0.50$</td> <td></td> <td>$N \leq 3$</td> </tr> <tr> <td>$0.50 < \phi$</td> <td></td> <td>0</td> </tr> </tbody> </table>		Size	Area	Acc. Qty	$\phi \leq 0.20$		Ignore	$0.20 < \phi \leq 0.50$		$N \leq 3$	$0.50 < \phi$		0		
Size	Area	Acc. Qty																	
$\phi \leq 0.20$		Ignore																	
$0.20 < \phi \leq 0.50$		$N \leq 3$																	
$0.50 < \phi$		0																	
02 Electrical Defect (Minor defect)		<table border="1" data-bbox="550 1556 1385 1729"> <thead> <tr> <th>Bright dot</th> <th>Display Area</th> <th>Total</th> <th rowspan="3">Note1</th> </tr> </thead> <tbody> <tr> <td></td> <td>$N \leq 2$</td> <td>$N \leq 2$</td> </tr> <tr> <td>Dark dot</td> <td>$N \leq 4$</td> <td>$N \leq 4$</td> </tr> <tr> <td>Total dot</td> <td>$N \leq 4$</td> <td>$N \leq 4$</td> <td></td> </tr> </tbody> </table> <p>Remark: 1. Bright dot caused by scratch and foreign object accords to item 1.</p>				Bright dot	Display Area	Total	Note1		$N \leq 2$	$N \leq 2$	Dark dot	$N \leq 4$	$N \leq 4$	Total dot	$N \leq 4$	$N \leq 4$	
Bright dot	Display Area	Total	Note1																
	$N \leq 2$	$N \leq 2$																	
Dark dot	$N \leq 4$	$N \leq 4$																	
Total dot	$N \leq 4$	$N \leq 4$																	

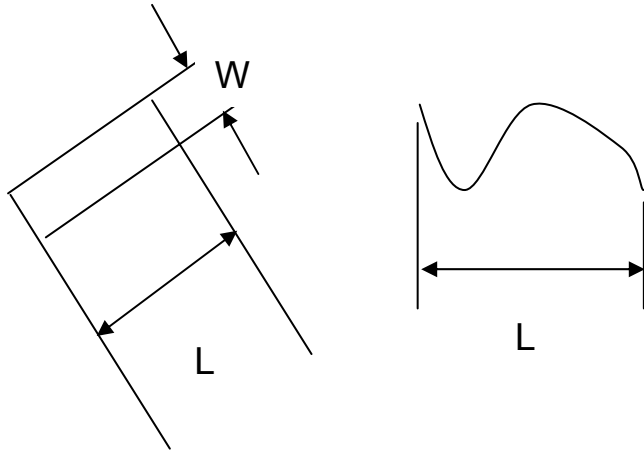
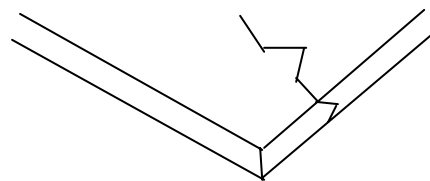
<p>03</p>	<p>Black and White line Scratch Foreign material (Line type) (Minor defect)</p>	 <table border="1" data-bbox="614 705 1236 974"> <thead> <tr> <th>Length</th> <th>Width</th> <th>Acc. Qty</th> </tr> </thead> <tbody> <tr> <td>/</td> <td>$W \leq 0.1$</td> <td>Ignore</td> </tr> <tr> <td>$L \leq 2.5$</td> <td>$0.1 < W \leq 0.2$</td> <td>3</td> </tr> <tr> <td>$L > 2.5$</td> <td>$0.2 < W$</td> <td>0</td> </tr> <tr> <td colspan="2">Total</td> <td>3</td> </tr> </tbody> </table> <p>Distance between 2 defects should more than 3mm apart. Scratches not viewable through the back of the display are acceptable.</p>	Length	Width	Acc. Qty	/	$W \leq 0.1$	Ignore	$L \leq 2.5$	$0.1 < W \leq 0.2$	3	$L > 2.5$	$0.2 < W$	0	Total		3
Length	Width	Acc. Qty															
/	$W \leq 0.1$	Ignore															
$L \leq 2.5$	$0.1 < W \leq 0.2$	3															
$L > 2.5$	$0.2 < W$	0															
Total		3															
<p>04</p>	<p>Glass Crack (Minor defect)</p>	 <p>Crack is potential to enlarge, any type is not allowed.</p>															

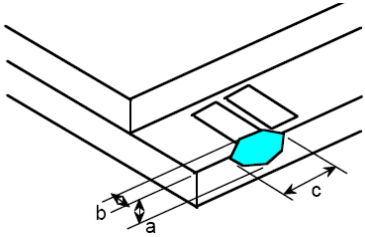
<p>05</p>	<p>Glass Chipping Pad Area: (Minor defect)</p> 	<table border="1" data-bbox="861 1657 1332 1825"> <thead> <tr> <th>Length and Width</th> <th>Acc. Qty</th> </tr> </thead> <tbody> <tr> <td>$c > 3.0, b < 1.0$</td> <td>1</td> </tr> <tr> <td>$c < 3.0, b < 1.0$</td> <td>3</td> </tr> <tr> <td colspan="2">$a < \text{Glass Thickness}$</td> </tr> </tbody> </table>	Length and Width	Acc. Qty	$c > 3.0, b < 1.0$	1	$c < 3.0, b < 1.0$	3	$a < \text{Glass Thickness}$	
Length and Width	Acc. Qty									
$c > 3.0, b < 1.0$	1									
$c < 3.0, b < 1.0$	3									
$a < \text{Glass Thickness}$										

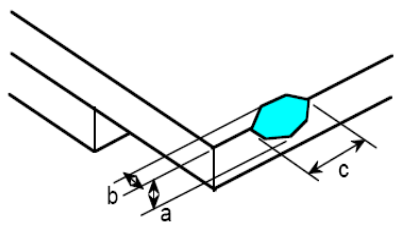
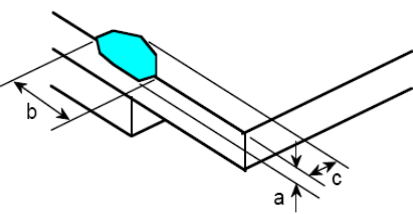
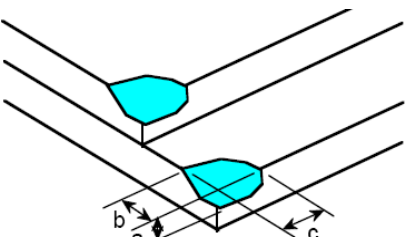
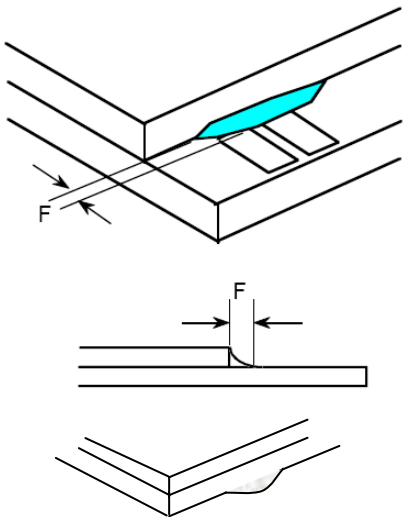
<p>06</p>	<p>Glass Chipping Rear of Pad Area: (Minor defect)</p> 	<table border="1"> <thead> <tr> <th>Length and Width</th> <th>Acc. Qty</th> </tr> </thead> <tbody> <tr> <td>$c > 3.0, b < 1.0$</td> <td>1</td> </tr> <tr> <td>$c < 3.0, b < 1.0$</td> <td>2</td> </tr> <tr> <td>$c < 3.0, b < 0.5$</td> <td>4</td> </tr> <tr> <td colspan="2">$a < \text{Glass Thickness}$</td> </tr> </tbody> </table>	Length and Width	Acc. Qty	$c > 3.0, b < 1.0$	1	$c < 3.0, b < 1.0$	2	$c < 3.0, b < 0.5$	4	$a < \text{Glass Thickness}$	
Length and Width	Acc. Qty											
$c > 3.0, b < 1.0$	1											
$c < 3.0, b < 1.0$	2											
$c < 3.0, b < 0.5$	4											
$a < \text{Glass Thickness}$												
<p>07</p>	<p>Glass Chipping Except Pad Area: (Minor defect)</p> 	<table border="1"> <thead> <tr> <th>Length and Width</th> <th>Acc. Qty</th> </tr> </thead> <tbody> <tr> <td>$c > 3.0, b < 1.0$</td> <td>1</td> </tr> <tr> <td>$c < 3.0, b < 1.0$</td> <td>2</td> </tr> <tr> <td>$c < 3.0, b < 0.5$</td> <td>4</td> </tr> <tr> <td colspan="2">$a < \text{Glass Thickness}$</td> </tr> </tbody> </table>	Length and Width	Acc. Qty	$c > 3.0, b < 1.0$	1	$c < 3.0, b < 1.0$	2	$c < 3.0, b < 0.5$	4	$a < \text{Glass Thickness}$	
Length and Width	Acc. Qty											
$c > 3.0, b < 1.0$	1											
$c < 3.0, b < 1.0$	2											
$c < 3.0, b < 0.5$	4											
$a < \text{Glass Thickness}$												
<p>08</p>	<p>Glass Corner Chipping: (Minor defect)</p> 	<table border="1"> <thead> <tr> <th>Length and Width</th> <th>Acc. Qty</th> </tr> </thead> <tbody> <tr> <td>$c < 3.0, b < 3.0$</td> <td>Ignore</td> </tr> <tr> <td colspan="2">$a < \text{Glass Thickness}$</td> </tr> </tbody> </table>	Length and Width	Acc. Qty	$c < 3.0, b < 3.0$	Ignore	$a < \text{Glass Thickness}$					
Length and Width	Acc. Qty											
$c < 3.0, b < 3.0$	Ignore											
$a < \text{Glass Thickness}$												
<p>09</p>	<p>Glass Burr: (Minor defect)</p> 	<table border="1"> <thead> <tr> <th>Length</th> <th>Acc. Qty</th> </tr> </thead> <tbody> <tr> <td>$F < 1.0$</td> <td>Ignore</td> </tr> </tbody> </table> <p>Glass burr don't affect assemble and module dimension.</p>	Length	Acc. Qty	$F < 1.0$	Ignore						
Length	Acc. Qty											
$F < 1.0$	Ignore											

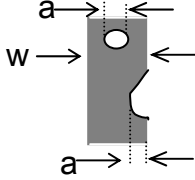
10	<p>FPC Defect: (Minor defect)</p> 	<p>10.1 Dent, pinhole width $a < w/3$. (w: circuitry width.) 10.2 Open circuit is unacceptable. 10.3 No oxidation, contamination and distortion.</p>								
11	Bubble on Polarizer (Minor defect)	<table border="1" data-bbox="737 660 1206 833"> <thead> <tr> <th>Diameter</th> <th>Acc. Qty</th> </tr> </thead> <tbody> <tr> <td>$\varphi \leq 0.30$</td> <td>Ignore</td> </tr> <tr> <td>$0.30 < \varphi \leq 0.50$</td> <td>$N \leq 2$</td> </tr> <tr> <td>$0.50 < \varphi$</td> <td>$N=0$</td> </tr> </tbody> </table>	Diameter	Acc. Qty	$\varphi \leq 0.30$	Ignore	$0.30 < \varphi \leq 0.50$	$N \leq 2$	$0.50 < \varphi$	$N=0$
Diameter	Acc. Qty									
$\varphi \leq 0.30$	Ignore									
$0.30 < \varphi \leq 0.50$	$N \leq 2$									
$0.50 < \varphi$	$N=0$									
12	Dent on Polarizer (Minor defect)	<table border="1" data-bbox="737 902 1206 1075"> <thead> <tr> <th>Diameter</th> <th>Acc. Qty</th> </tr> </thead> <tbody> <tr> <td>$\varphi \leq 0.25$</td> <td>Ignore</td> </tr> <tr> <td>$0.25 < \varphi \leq 0.50$</td> <td>$N \leq 4$</td> </tr> <tr> <td>$0.50 < \varphi$</td> <td>None</td> </tr> </tbody> </table>	Diameter	Acc. Qty	$\varphi \leq 0.25$	Ignore	$0.25 < \varphi \leq 0.50$	$N \leq 4$	$0.50 < \varphi$	None
Diameter	Acc. Qty									
$\varphi \leq 0.25$	Ignore									
$0.25 < \varphi \leq 0.50$	$N \leq 4$									
$0.50 < \varphi$	None									
13	Bezel	<p>13.1 No rust, distortion on the Bezel. 13.2 No visible fingerprints, stains or other contamination.</p>								
14	Touch Panel	<p>D: Diameter W: width L: length 14.1 Spot: $D < 0.25$ is acceptable $0.25 \leq D \leq 0.4$ 2dots are acceptable and the distance between defects should more than 10 mm. $D > 0.4$ is unacceptable 14.2 Dent: $D > 0.40$ is unacceptable 14.3 Scratch: $W \leq 0.03$, $L \leq 10$ is acceptable, $0.03 < W \leq 0.10$, $L \leq 10$ is acceptable Distance between 2 defects should more than 10 mm. $W > 0.10$ is unacceptable.</p>								
15	PCB	<p>15.1 No distortion or contamination on PCB terminals. 15.2 All components on PCB must same as documented on the BOM/component layout. 15.3 Follow IPC-A-600F.</p>								

16	Soldering	Follow IPC-A-610C standard
17	Electrical Defect (Major defect)	<p>The below defects must be rejected.</p> <p>17.1 Missing vertical / horizontal segment, 17.2 Abnormal Display. 17.3 No function or no display. 17.4 Current exceeds product specifications. 17.5 LCD viewing angle defect. 17.6 No Backlight. 17.7 Dark Backlight. 17.8 Touch Panel no function.</p>

Remark: LCD Panel Broken shall be rejected. Defect out of LCD viewing area is acceptable.

10.7 Classification of Defects

10.7.1 Visual defects (Except no / wrong label) are treated as minor defect and electrical defect is major.

10.7.2 Two minor defects are equal to one major in lot sampling inspection.

10.8 Identification/marketing criteria

Any unit with illegible / wrong /double or no marking/ label shall be rejected.

10.9 Packing

10.9.1 There should be no damage of the outside carton box, each packaging box should have one identical label.

10.9.2 Modules inside package box should have compliant mark.

10.9.3 All direct package materials shall offer ESD protection

Note1:Bright dot is defined as the defective area of the dot is larger than 50% of one sub-pixel area.

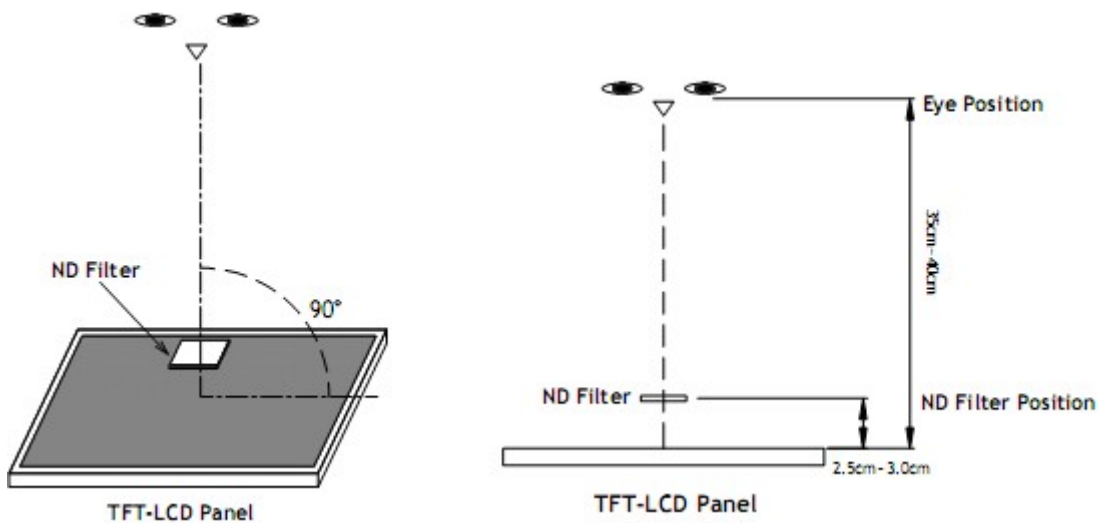

Bright dot:The bright dot size defect at black display pattern.It can be recognized by 2% transparency of filter when the distance between eyes and panel is 350mm ± 50mm.

Dark dot:Cyan,Magenta or Yellow dot size defect at white display pattern.It can be recognized by 5% transparency of filter when the distance between eyes and panel is 350mm ± 50mm.

11. Reliability Specification

No	Item	Condition	Quantity
1	High Temperature Operating	70°C, 96Hrs	5
2	Low Temperature Operating	-20°C, 96Hrs	5
3	High Humidity	50°C, 90%RH, 96Hrs	5
4	High Temperature Storage	80°C, 96Hrs	5
5	Low Temperature Storage	-30°C, 96Hrs	5
6	Thermal shock	-20°C, 30min~70°C, 30min, 20 cycles.	5

Note1. No deflection cosmetic and operational function allowable.

Note2. Total current Consumption should be below double of initial value

12. Precautions and Warranty

12.1 Safety

12.1.1 The liquid crystal in the LCD is poisonous. Do not put it in your mouth. If the liquid crystal touches your skin or clothes, wash it off immediately using soap and water.

12.1.2 Since the liquid crystal cells are made of glass, do not apply strong impact on them. Handle with care.

12.2 Handling

12.2.1 Reverse and use within ratings in order to keep performance and prevent damage.

12.2.2 Do not wipe the polarizer with dry cloth, as it might cause scratch. If the surface of the LCD needs to be cleaned, wipe it swiftly with cotton or other soft cloth soaked with petroleum IPA, do not use other chemicals.

12.3 Storage

12.3.1 Do not store the LCD module beyond the specified temperature ranges.

12.4 Metal Pin (Apply to Products with Metal Pins)

12.4.1 Pins of LCD and Backlight

12.4.1.1 Solder tip can touch and press on the tip of Pin LEAD during the soldering

12.4.1.2 Recommended Soldering Conditions

Solder Type: Sn96.3~94-Ag3.3~4.3-Cu0.4~1.1

Maximum Solder Temperature: 370°C

Maximum Solder Time: 3s at the maximum temperature

Recommended Soldering Temp: 350±20°C

Typical Soldering Time: ≤3s

12.4.1.3 Solder Wetting

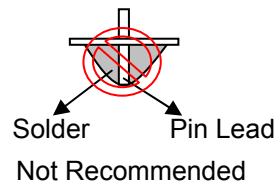
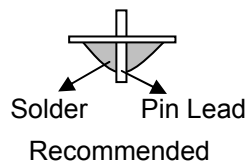

12.4.1 Pins of EL

12.4.2.1 Solder tip can touch and press on the tip of EL leads during soldering.

12.4.2.2 No Solder Paste on the soldering pad on the motherboard is recommended.

12.4.2.3 Recommended Soldering Conditions

Solder type: Nippon Alimit Leadfree SR-34, size 0.5mm

Recommended Solder Temperature: 270~290°C

Typical Soldering Time: ≤2s

Minimum solder distance from EL lamp (body):2.0mm

12.4.2.4 No horizontal press on the EL leads during soldering.

12.4.2.5 180° bend EL leads three times is not allowed.

12.4.2.6 Solder Wetting

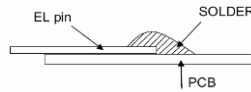

Recommended

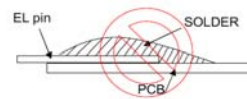

Not Recommended

12.4.2.7 The type of the solder iron:

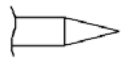

Recommended

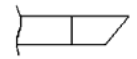

Not Recommended

12.4.2.8 Solder Pad

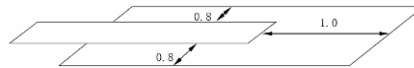

12.5 Operation

- 12.5.1 Do not drive LCD with DC voltage
- 12.5.2 Response time will increase below lower temperature
- 12.5.3 Display may change color with different temperature
- 12.5.4 Mechanical disturbance during operation, such as pressing on the display area, may cause the segments to appear "fractured".

12.6 Static Electricity

- 12.6.1 CMOS LSIs are equipped in this unit, so care must be taken to avoid the electro-static charge, by ground human body, etc.
- 12.6.2 The normal static prevention measures should be observed for work clothes and benches.
- 12.6.3 The module should be kept into anti-static bags or other containers resistant to static for storage.

12.7 Limited Warranty

- 12.7.1 Our warranty liability is limited to repair and/or replacement. We will not be responsible for any consequential loss.
- 12.7.2 If possible, we suggest customer to use up all modules in six months. If the module storage time over twelve months, we suggest that recheck it before the module be used

13. Packaging

TBD

14. Outline Drawing

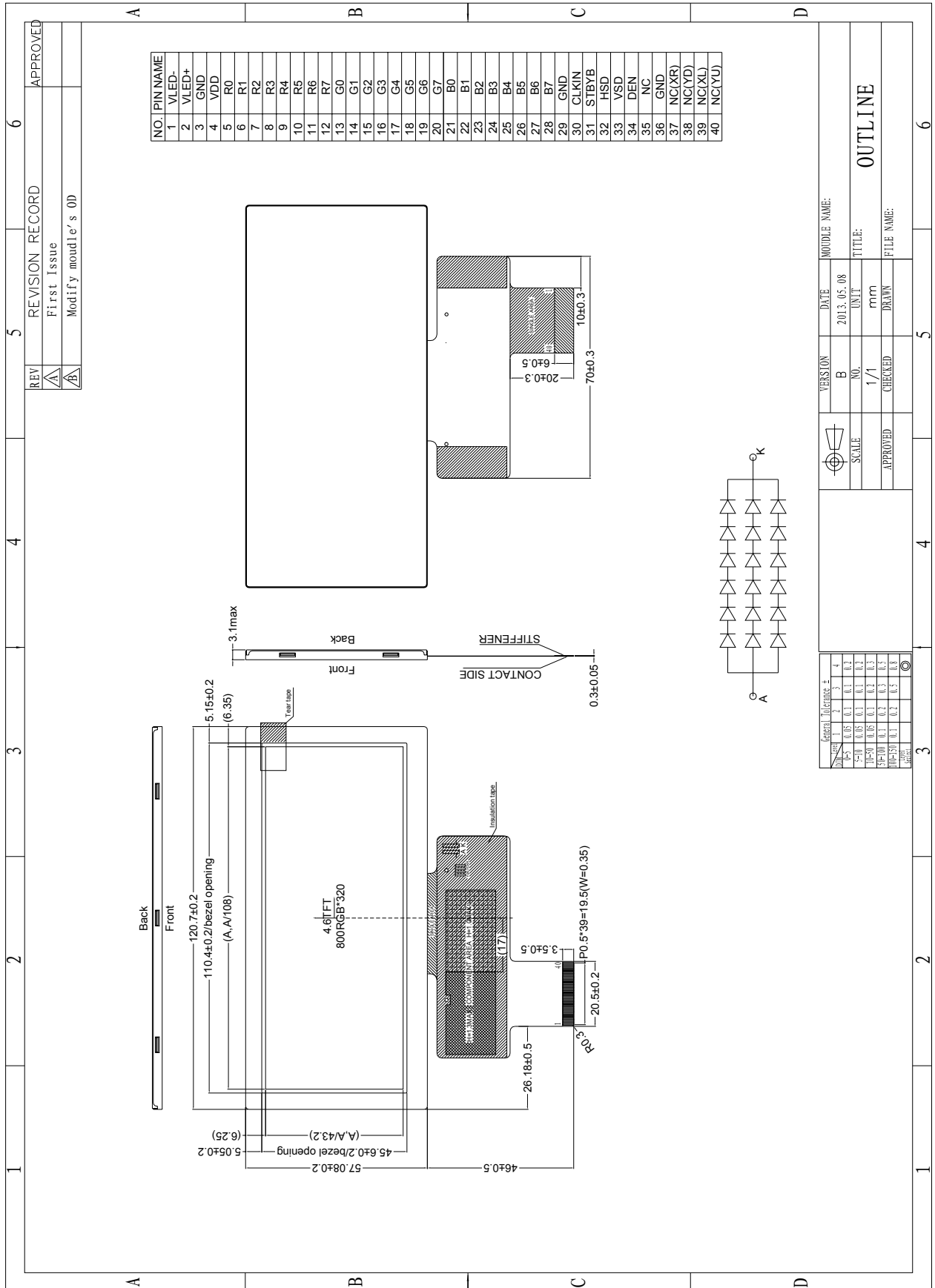

REV	REVISION RECORD	APPROVED
A	First Issue	
B	Modify mould'e's 0D	

VERSION	DATE	MODULE NAME:
B	2013.05.08	
NO.	UNIT	TITLE:
1/1	mm	OUTLINE
CHECKED	DRAWN	FILE NAME: